

## IMPACT OF WORK-FAMILY DEMAND ON WELL-BEING OF HOTEL EMPLOYEES

Teo Lee Ping<sup>1</sup>, Nur Fatihah Abdullah Bandar<sup>2</sup>, Zaiton Hassan<sup>3</sup>, Surena Sabil<sup>4</sup>,  
Dyg Kartini Abg Ibrahim<sup>5</sup>, Abdul Hafaz Ngah<sup>6</sup>

<sup>1</sup>Faculty of Cognitive Sciences and Human Development, Universiti Malaysia Sarawak, 94300 Kota Samarahan, Sarawak, Malaysia.

<sup>2</sup>Faculty of Cognitive Sciences and Human Development, Universiti Malaysia Sarawak, 94300 Kota Samarahan, Sarawak, Malaysia. E-mail: abnfatihah@unimas.my

<sup>3</sup>Faculty of Cognitive Sciences and Human Development, Universiti Malaysia Sarawak, 94300 Kota Samarahan, Sarawak, Malaysia.

<sup>4</sup>Faculty of Cognitive Sciences and Human Development, Universiti Malaysia Sarawak, 94300 Kota Samarahan, Sarawak, Malaysia.

<sup>5</sup>Faculty of Cognitive Sciences and Human Development, Universiti Malaysia Sarawak, 94300 Kota Samarahan, Sarawak, Malaysia.

<sup>6</sup>Department of Maritime Management, Universiti Malaysia Terengganu, Malaysia.

### ABSTRACT

Many employees are oppressed between struggling cumbersome workloads and family responsibilities, thus pursuing a good work-life balance is the priority to achieve healthy well-being. Additionally, workplace flexibility is vital to alleviate work-family conflict and promote employees' well-being. This study aims to investigate the relationship between work-family demands and well-being with the moderating effect of workplace flexibility. Self-administered survey questionnaires are utilized for data collection among 85 frontline employees from the selected hospitality industry in Kuching, Sarawak. The study applies structural equation modelling (SEM) approach with Smart Partial Least Squares (PLS) to test the hypothesis developed in the research framework. It can be confirmed that work-family demands are negatively influence on well-being and workplace flexibility is not the moderator between Work-family demands and well-being. The results will become attention for the management of the hospitality industry and human resource practitioners who are concerned with promoting employees' well-being.

**Keywords:** Hospitality, Workplace Flexibility, Human Resource, Sarawak, Malaysia.

### I. INTRODUCTION

Improvement of community well-being provide opportunities to achieve employee greater success. Ensuring healthy lives and promoting the well-being is an essential to sustainability development. This study will focus on well-being of front-line employees in selected Hotels in Sarawak. The working environment in the hospitality industry is deemed as labor-intensive which in turn means that human efforts are rendered the services to the hospitality establishments.

(Gamor, Amisshah, Amisshah, & Nartey, 2017; Kong, Jiang, Chan, & Zhou, 2018). Undoubtedly, a relentless 24/7 work culture such as hospitality industry has necessitated most of the employees frequently work on around-the-clock basis and sacrifice their family and personal life in an attempt to assure the service quality (Lin, Wong, & Ho, 2015; Zhao, Qu, & Ghiselli, 2011; Cleveland et al., 2007). Specifically, hospitality employees such as frontline employees so-called service providers with customer-oriented employees usually deal with high pressure working conditions and often face difficulties to struggle with work-family demands for achieving healthy well-being (Lin et al., 2015; Chiang, Birtch, & Cai, 2014; Gamor et al., 2017; Cleveland et al., 2007; Wong & Lin, 2007). They are identified as lengthy work duration, inflexible working arrangements, burdensome workloads, difficult work demands, on-call hours, holiday work and split shift (Zhao, 2016; Dawson, Abbott, & Shoemaker, 2011; Zhao & Ghiselli, 2016). Given the nature of job and responsibilities, these working conditions

induced the discordance within work and family demands which ultimately experienced work-family conflict (WFC) (Gamor et al., 2017). Despite the work demands, increased family demands also generated the emergence of family-work conflict (FWC) (Gamor et al., 2017; Michel, Kotrba, Mitchelson, Clark, & Baltes, 2011). Most of the prior researchers which measure family demands by depending on the objective indicators such as the number and age of children (Annor, 2016; Achour, Shahidra Abdul Khalil, Bahiyah Ahmad, Mohd Roslan Mohd Nor, & Mohd Yakub Zulkifli Mohd Yusoff, 2017; Gjerberg, 2003). Family with children are vulnerable to FWC (Netemeyer, Boles, & McMurrian, 1996) whereas a family with children at the age of 3 years old or below are more susceptible to FWC (Gamor et al., 2017) as they may necessitate spending more time and attention for their younger children (Annor, 2016). In addition, the employees who are overburdened by family responsibilities, they have more tendency to function sub-optimally in the work domain and experience interference from family to work (Edwards & Rothbard, 2000). WFC is considered as a pervasive life phenomenon in the contemporary era (Achour et al., 2017; Akkas, Mohammad Ikbal Hossain, & Rhaman, 2015). Approximately 40% to 78% of the employed parents are more likely to confront WFC in their marriage (Kinnunen & Mauno, 1998) and considered as a predominant issue in Malaysia (Noorfadhila Zakaria & Zanariah Ismail, 2017). In line with Pew Research Center (2013) from an international context, 60% of the employed fathers and 47% of the employed mothers claimed that they are experienced WFC. Among the working parents with younger children, 15% of them said it is very difficult and 37% of them said it is somewhat difficult to struggle with their work and family demands in equilibrium. These negative impacts of WFC could generate some detrimental effects on well-being (Akkas et al., 2015; Cleveland et al., 2007) in terms of job satisfaction, family satisfaction and life satisfaction (Achour et al., 2017). Nonetheless, workplace flexibility is provided for the employees under the umbrella of employee well-being policies in the organization and probably to alleviate WFC (Rastogi, Rangnekar, & Rastogi, 2018; Erden Bayazit & Bayazit, 2017; McNall, Masuda, & Nicklin, 2010; Lu, Kao, Chang, Wu, & Cooper, 2008). Moreover, researchers have recommended that future empirical studies should consider workplace flexibility as a dominant factor to deal with work-family demands and well-being (Achour et al., 2017). Hence, it is a necessity to investigate the relationship between work-family demands and well-being among frontline employees in the hospitality industry with the moderating effect of workplace flexibility.

## II. LITERATURE REVIEW

### 1.1 Work-Family Demands and Well-being

In today's turbulent and troubled working environment, employees are struggling between work and family demands. The conflicts caused by work and family demands are recognized as serious and momentous issues in the contemporary era (Achour, Mohd Roslan Mohd Nor, & Mohd Yakub Zulkifli Mohd Yusoff, 2013). Achour, Grine, and Mohd Roslan Mohd Nor (2014) presumed that an individual possesses limited of the psychological and physiological resources to consume on the role performances. Thus, any contradictive work and family demands that beyond limited of the psychological and physiological resources will cause conflicts either work-to-family conflict or vice versa which in turn negatively affect well-being. As argued by Boyar, Maertz, Mosley, and Carr (2008), work and family demands also identified as the primary causes of work-family conflict (WFC). The detrimental effects on well-being that produced from the occurrence of WFC comprise job dissatisfaction, family dissatisfaction and life dissatisfaction (Achour et al., 2017). The recent study conducted by Achour et al. (2017) in the Malaysian context emphasized the dominant factors of WFC such as lengthy work duration, work overload, household chores and children-related matters to investigate the relationship between work-family demands and well-being. The researchers asserted that work-family demands and WFC are negatively correlated with well-being and interrelated with job dissatisfaction, family dissatisfaction and life dissatisfaction. Previous research also found that the impacts of work-family demands are significant and negatively associated with life satisfaction particularly for female employees (Achour, Nor, & Mohd Yusoff, 2013). High levels of WFC is positively correlated with long work duration, inflexible working arrangements, work overload and parental demands. The empirical research done by Lu et al. (2008) is to probe into the relationship between work-family demands, WFC and work-related consequences in the case of Taiwan. The findings manifested that work demands are positively linked to WFC whereas work and family demands are positively interrelated with family-work conflict (FWC). Researchers also indicated that the antecedents of WFC are work length and workload whereas the antecedent of FWC is the number of dependents. Based on the findings, it also clarified that WFC is negatively correlated with job satisfaction and FWC is negatively interrelated with organizational commitment.

Based on the above literature, work-family demands can be devised to associate with well-being. Hence, the following hypothesis has been formulated.

Hypothesis 1. Work-family demands are negatively influence on well-being.

### 1.2 The Moderating Effect of Workplace Flexibility

Many employees are torn between struggling oppressive workloads and family obligations in today's rapid paced and chaotic working atmosphere. The pursuit of work-life balance seems like an impossible feat. Nevertheless, striking a good work-life balance is the priority to achieve healthy well-being. The presence of workplace flexibility is vital to manage the work-life balance (Rastogi et al., 2018; Jeffrey Hill, Hawkins, Ferris, & Weitzman, 2001). In fact, the availability of workplace flexibility produces resources to better equip employees to cope with work-family demands (McNall et al., 2010). Therefore, the notion of work-life balance is conducive for the employees to achieve healthy well-being. The recent study done by Rastogi et al. (2018) in the Indian context claimed that supportive workplace policies which are provided organizational advantages in conformity with employees' needs such as temporal flexibility and operational flexibility are certainly vital to assist the employees in dealing with work-family demands and reinforcing their quality of work life. Preliminary research also manifested that the practicality of workplace flexibility improves work-family enrichment and associated with higher job satisfaction and lower turnover intentions (McNall et al., 2010). There is robust evidence to indicate that workplace flexibility can hinder the occurrence of work-family conflict (WFC) and family-work conflict through their research study. They also reported that the impetus to invent the workplace flexibility is assisting employees to manage the work-life balance. As discussed by Lu et al. (2008), workplace flexibility can alleviate WFC and hence improve job satisfaction and organizational commitment. Based on the occupational stress perspective, it is crucial to recognize and cultivate resources such as applying the workplace flexibility practices for achieving healthy well-being (Lu et al., 2008). Halpern (2005) also examined how workplace flexibility relieves stress, increases health and saves monetary expenses. Based on the results of his empirical research, it reported that workplace flexibility is positively correlated with stress relief, enhancement in health and saving of monetary expenses. When the employees are in healthy conditions, they tend to lesser absenteeism, increased organizational commitment and decreased health care cost and thus will gratify their personal, work and family domains. Employees with perceived workplace flexibility able to enhance their work-life balance through the mechanism of positive spillover (Jeffrey Hill et al., 2001). The rationale of this study specified that workplace flexibility allowed employees to fulfil family obligations such as participate in family-related matters, facilitate child care and take responsibilities for elder care.

According to the fundamental of the above literature, workplace flexibility can be devised to moderate the relationship between work-family demands and well-being. Therefore, the following hypothesis has been formulated.

Hypothesis 2. Workplace flexibility moderates the relationship between work-family demands and well-being.

In order to examine the abovementioned hypotheses, a conceptual framework is proposed (Figure 1).

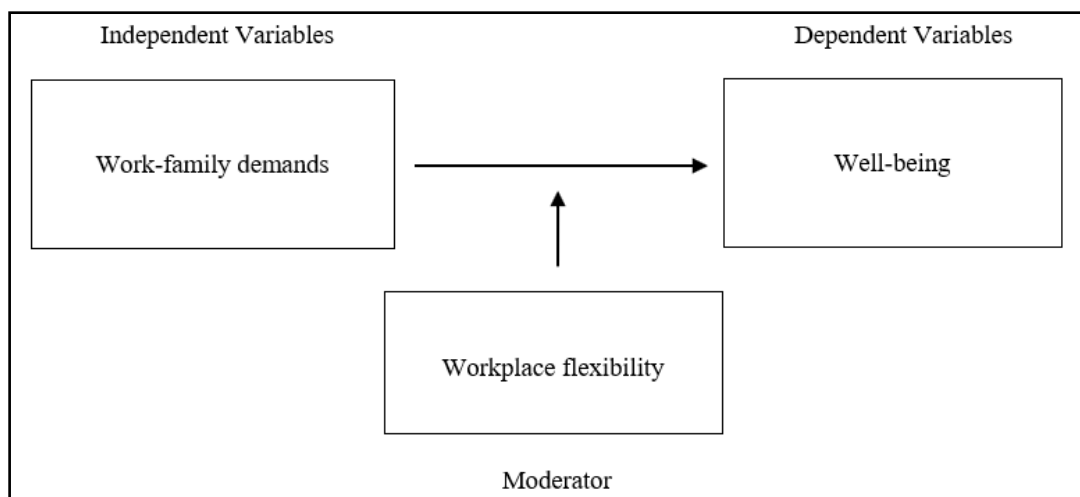

Figure 1. Hypotheses Model

## III. METHODS

### 1.1 Participants and Procedure

The sampling procedure is described as the process of choosing a plentiful number of the right subjects from the entire population (Sekaran & Bougie, 2016). Therefore, the studied sample granted to represent the properties or characteristics of the population elements to which they are pertained to. In this study, the sampling procedure is identified as probability sampling. Probability sampling is explained as the probability of choosing the members of the population is determinable or form a subgroup of the population in a random manner (Sekaran & Bougie, 2016). Since this research is quantitative in nature, thus the researcher is primarily emphasized adopting the probability sampling such as random sampling. Random sampling is specified as “every element in the population has a known and equal chance of being selected as a subject” (Sekaran & Bougie, 2016, p. 242). Accordingly, every member of the population has an independent chance of being chosen when random sampling is applied. In this research, the members of the sample are confined to 100 frontline employees who are working in the hospitality industry.

A total of 16 selected hospitality industry in Kuching, Sarawak are participated in the current study. Having participants from numerous hospitality industry are crucial to ensure that the sample is able to epitomize the population of the hospitality industry. The researcher has distributed 100 survey questionnaires to the respondents who meet the criteria of the sample. A total of 94 survey questionnaires are returned which indicated a response rate of 94%. Nonetheless, 9 responses were discarded from the returned survey questionnaires. This is due to the fact that 7 respondents provide consistent answers on all the Likert scale items and 2 survey questionnaires are partially answered as more than 25% of the questions are left blank. Thus, there are only 85 applicable survey questionnaires are utilized in the final data analysis which accounted for 85% of the response rate.

## 1.2 Measures

It is inevitable to devise the survey questionnaire in some degree to acquire the precise information relevant to the research problem and encourage the respondents to participate in this study. The survey questionnaire is designed which consistent with the research hypotheses and the question items are adopted from the prior published literature (Boyar, Carr, Mosley, & Carson, 2007; Carlson, Kacmar, & Williams, 2000; Rastogi et al., 2018; Steffgen, Kohl, Reese, Happ, & Sischka, 2015; Zabriskie & Ward, 2013; Margolis, Schwitzgebel, Ozer, & Lyubomirsky, 2018) as well as the instruction suggested in order to obtain better response outcomes. It is obligatory to adapt some wording of the question items in order to assure the question items are unambiguous, simple and straightforward. Thus, the respondents can easily comprehend the questions as well as minimize the possibility of misinterpretations.

The survey questionnaire consists of five main sections which incorporated demographic profile and four constructs of the variables of interest. The demographic profile encompassed age, gender, ethnicity, religion, marital status, length of marriage, number of children, age of eldest children, age of youngest children, length of service, working arrangement and live in maid whereas the constructs of the variables of interest comprised work-family demands, work-family conflict, workplace flexibility and well-being. Moreover, the researcher utilized closed-ended questions with response scales format as it emphasized devising a set of normalized answers for the respondents to conclude and relatively easier to answer as compared to the open-ended questions (Moy & Murphy, 2016). Hence, the respondents are required a lesser amount of effort and consideration to complete the survey questionnaire. This also can encourage the respondents to participate in the study and eliminate response bias. Scaled-response questions are applied as it concentrates on the scale measurement which enables to illustrate the extent to which the respondents agree with the question items. It also can promote the solicitation of responses and decrease the overall time required for answering the questionnaire (Moy & Murphy, 2016). The items in the questionnaire are designed by utilizing appropriate response scales. Therefore, the respondents are encouraged to provide more precise answers as well as assure the relevancy and accuracy of the data analysis.

There are three scales employed in this research which incorporated nominal, ratio and ordinal with Likert scale. The application of a nominal scale is restricted to question items relevant to the demographic profile of respondents such as gender, ethnicity, religion, marital status, working arrangement and live in maid. Furthermore, the ratio scale is adopted for the questions that asked for respondents' age, length of marriage, number of children, age of eldest children, age of youngest children and length of service. Ordinal with the Likert scale is used for the questions that probed into the respondents' perceptions regarding the variables of interest. The question items for the constructs of work-family demands and work-family conflict are evaluated employing five-point Likert scale with 1 = strongly disagree and 5 = strongly agree whereas the measurement of five-point Likert scale with 1 = never and 5 = always is applied to the construct of workplace flexibility. Seven-point Likert

scale with 1 = strongly disagree and 7 = strongly agree is scored on the question items for the construct of well-being (Steffgen et al. 2015; Zabriskie and Ward ,2013; Margolis et al. 2018).

### 1.3 Data Analysis

Data are analyzed by using Statistical Package for the Social Sciences (SPSS) 24. In the current study, the proposed conceptual framework is analyzed by employing the Pearson product-moment correlation coefficient - and hierarchical multiple regression for hypothesis 1 and hypothesis 2 respectively.

## IV. RESULTS

The results of the multivariate skewness and kurtosis indicate that the Mardia’s multivariate skewness ( $\beta = 13.136, p < 0.01$ ) and Mardia’s multivariate kurtosis ( $\beta = 61.833, p < 0.01$ ). Kline (2011) proposed that the data is normal if the skewness is  $\pm 1$ , and kurtosis is  $\pm 7$ . Thus, the data was slightly multivariate not normal, which suitable to apply the Smart PLS software; which known as suitable non-parametric test of the study.

There are two steps of the analysis; which is measurement model, which must be passed before continuing to the structural model testing.

### 1.4 Measurement Model

Measurement model concerned on the correlation between the items and the construct in the research framework to ensure validities has been met for the study. There are two types of validities which are, the convergent validity and the discriminant validity. Convergent validity will confirm that the multiple items used in the study really measured the construct that it supposed to measure. The convergent validity will be established if the loading and the average variance extracted (AVE) is  $\geq$  than 0.5, and the Composite Reliability (CR) is  $\geq$  than 0.7(Hair Jr, Sarstedt, Hopkins, & G. Kuppelwieser, 2014). According to the Table 1, all the loadings and the AVE are higher than 0.5, CR also more than 0.7, thus indicating that the convergent validity has been ascertain for the study. Figure 1 shows the measurement model of the study.

**Table 1.**Measurement Model

		Convergent Validity			
First Order Construct	Second Order Construct	Loading	CR	AVE	
Job Satisfaction	WB1	0.890	0.943	0.770	
	WB2	0.932			
	WB3	0.888			
	WB4	0.863			
	WB5	0.809			
Family Satisfaction	WB6	0.852	0.899	0.643	
	WB7	0.923			
	WB8	0.850			
	WB9	0.667			
	WB10	0.687			
Life Satisfaction	WB11	0.916	0.922	0.797	
	WB12	0.907			
	WB14	0.853			
	Well-being	Job Satisfaction			0.844
Family Satisfaction	0.871				
Life Satisfaction	0.826				
Work Flexibility	WF1	0.639	0.753	0.508	
	WF2	0.648			
	WF4	0.834			
Work Demand	WFD1	0.725			0.917
	WFD2	0.852			
	WFD3	0.878			
	WFD4	0.850			
	WFD5	0.839			
Family Demand	WFD6	0.786	0.864	0.614	
	WFD7	0.762			
	WFD8	0.842			
	WFD9	0.740			
	Work-Family Demand	Work Demand	0.923	0.881	0.787

Family Demand	0.850
---------------	-------

Next, the discriminant validity is perform to ensure that the construct truly differ from other construct. To ensure the results is reliable, accurate assessment on this part is crucial to ensure the constructs are really unique (Hair, Sarstedt, & Ringle, 2019). Due to that matter, Henseler, Ringle, and Sarstedt (2014) proposed to use Heterotrait-monotrait (HTMT) ratio instead of other methods. Discriminant validity is not a problem for the study if all values in the table are less than 0.85 (Franke & Sarstedt, 2018). Since all values in the Table 2 are less than the threshold value of 0.85, set by Franke and Sarstedt (2018), hence it shows that the discriminant validity has been established for the study.

**Table 2.**Discriminant Validity (HTMT)

Construct	1	2	3	4	5	6
Family Demand 1/						
Family Satisfaction 2)	0.535					
Flexibility 3)	0.151	0.148				
Job Satisfaction 4)	0.317	0.602	0.101			
Life Satisfaction 5)	0.548	0.756	0.279	0.583		
Work demand 6)	0.677	0.382	0.136	0.173	0.374	

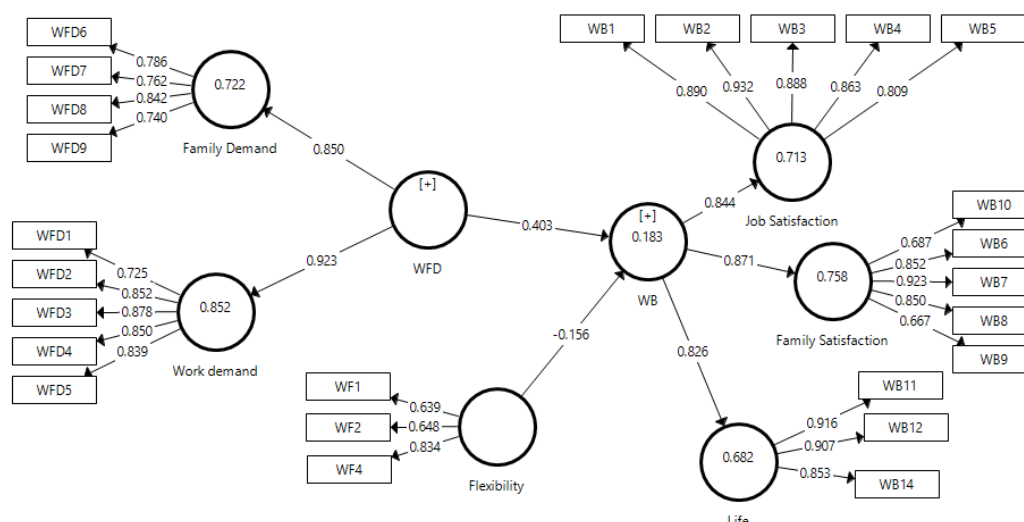

**Figure 1.** Measurement Model

#### 4.2 Structural Model

Lateral collinearity must be freed before assessing the structural model of the study. Diamantopoulos and Siguaw (2006) proposed that the Variance Inflated factor (VIF) should be  $\geq 3.3$  to ensure that collinearity is not a big issue for the study. As seen in the Table 3, the VIF values are less than 3.3, thus confirming that the collinearity is not a threat for the study. To test the hypothesis of the study, bootstrapping process with 500 resampling techniques as suggested by Hair, Hollingsworth, Randolph, and Chong (2017) was applied. The study found that the direct hypothesis was supported pay ( $\beta = 0.403$ ,  $t = 3.981$ : LL = 0.242, UL = 0.565,  $P < 0.01$ ), and the moderating hypothesis was unsupported ( $\beta = -0.036$ ,  $t = 0.278$ : LL = -0.242, UL = 0.195,  $P < 0.391$ ), thus it can be confirmed that H1 was supported, and H2 was unsupported.

**Table 3.**Path Coefficient

H'thesis	Relationshipp	Beta	Se	T value	P Values	LL	UL	Decision	VIF
H1	<b>WFD -&gt; WB</b>	0.403	0.101	3.981	<b>0.001</b>	0.242	0.565	Supported	1.000
H2	<b>WFD * Flexibility -&gt; WB</b>	-0.036	0.129	0.278	<b>0.391</b>	-0.242	0.195	Unsupported	

The  $R^2$  of 0.183 shows that 18.3% of the variance in well-being can be explained by WFD. According to Cohen (1988),  $R^2$  values for endogenous construct are assess as substantial, moderate and weak by 0.26, 0.13 and 0.02 respectively. Hence it can consider that the  $R^2$  of the study is at the moderate in terms of the explanatory power. To measure the effect size ( $f^2$ ), the measurement by(Cohen, 1988) indicate that 0.02 as a small, 0.15 as medium and 0.35 considered as large. Since the  $f^2$  value of the study is at 0.199, it can be claimed that the effect size of the WFD towards the WB is at the medium level. Lastly, as mentioned, the purpose of the study is for the

predictive purpose. Hence, the Predictive relevance ( $Q^2$ ) was run to test the model predictive relevance. Hair et al. (2017) proposed that if the  $Q^2$  from the blindfolding techniques is  $\geq 0$ , indicating that the model has a predictive relevance. The  $Q^2$  of the study is at 0.083, thus indicating that the model has a predictive relevance. Table 4 illustrates all the results for the Variance explain ( $R^2$ ), Predictive Relevance ( $Q^2$ ) and Effect size ( $f^2$ ) of the study.

**Table 4.** Variance explain ( $R^2$ ), Predictive Relevance ( $Q^2$ ) and Effect size ( $f^2$ )

Construct	$R^2$	$Q^2$	$f^2$	Decision
WB	0.183			
WFD		0.083	0.199	Medium

## V. DISCUSSION

The current study is contributed to the work-family and well-being literature by clarifying the direct effect between work-family demands and well-being as well as the moderating effect of workplace flexibility in the relationship between work-family demands and well-being among frontline employees in the hospitality industry. As a result, all hypotheses formulated to guide the research study are supported.

### 1.1 Work-family Demands and Well-being

The results indicated that work-family demands are exerted a significant and moderate negative effect on well-being among frontline employees in the hospitality industry. The results are supported and consistent with the previous findings of other researchers (Achour et al., 2017; Achour et al., 2013; Lu et al., 2008). Achour et al. (2014) presumed that an individual possesses limited of the psychological and physiological resources to consume on the role performances. Accordingly, when the individual experiences increased role demands in one domain, he/she may tend to promote the process of resources drain and decrease the availability of the resources in another domain in order to cope with such demands (Furtado, Sobral, & Peci, 2016). These situations will restrict an individual's competence to gratify the desires in another domain (Annor, 2016). This is due to the fact that the individual is depleted the scarce resources from another domain to deal with the desires of the demanding domain. In the same way, when the individual confronts unbearable demands due to the higher role expectations within a specific domain, he/she may suffer from increased role pressures (Greenhaus & Beutell, 1985). Consequently, any contradictive work and family demands that beyond limited of the psychological and physiological resources will cause conflicts either work-to-family conflict or vice versa which in turn negatively affect well-being.

The findings of the present study demonstrated that the higher the perception of the work-family demands are correlated with the lower the perception of the well-being among frontline employees in the hospitality industry. Indeed, the hospitality industry is characterized as relentless 24/7 work culture which means that operate 24/7 and 365 days per year inclusive of weekends and public holidays. Moreover, employees who hold boundary-spanning roles are identified as frontline employees. Given the nature of work culture and their boundary-spanning roles, they are necessitated to frequently work on around-the-clock basis and sacrifice their family and personal life in an attempt to assure the service quality (Lin et al., 2015; Zhao et al., 2011) such as face-to-face encounter and phone encounter with customers in order to deal with miscellaneous customers' inquiries and complaints (Karatepe & Baddar, 2006). In particular, frontline service positions are recognized as lengthy work duration, inflexible working arrangements, burdensome workloads, difficult work demands, on-call hours, holiday work and split shift (Zhao, 2016; Dawson et al., 2011; Zhao & Ghiselli, 2016). Gamor et al. (2017) specified that these working conditions triggered the discordance within work and family demands which ultimately experienced WFC. The results are supported by the spillover theory which postulated that the consequences of WFC can spillover and negatively affect well-being such as job stress, occupational burnout, absenteeism, turnover intentions, family distress, emotional exhaustion and mental illness (Akkas et al., 2015; Cleveland et al., 2007). This emphasizes the consequences of work-family demands in the hospitality industry. Therefore, it is crucial to decrease the work-family demands and prioritize employees' well-being which will contribute to more desirable outcomes such as increase employees' overall satisfaction and improve employee retention.

### 1.2 The Moderating Effect of Workplace Flexibility

The present study also further emphasized on the significance of workplace flexibility as there is a potentially significant moderating effect of workplace flexibility in the relationship between work-family demands and well-being. The results are not supported and this result contradict with the preliminary findings of other researchers (Rastogi et al., 2018; McNall et al., 2010; Lu et al., 2008). Many employees are persecuted between struggling

burdensome workloads and family obligations, thus pursuing a good work-life balance is the priority to achieve healthy well-being. The presence of workplace flexibility is crucial to manage the work-life balance (Rastogi et al., 2018; Jeffrey Hill et al., 2001). In nature, the availability of workplace flexibility produces resources to better equip employees to cope with work-family demands (McNall et al., 2010). The hypothesis is not supported due to others potential moderator might enhance the relationship between work family demands and well-being. These can be explained by front line nature of work considered as flexible as compared to other industries and job positions.

### 1.3 Implications

The findings of this study contribute some important research implications to the theory and practices. From the theoretical perspective, the proposed conceptual framework is underpinned by the spillover theory. The spillover theory is employed to better grasp on the constructs of negative spillover. In the current study, the data analysis revealed that the proposed conceptual framework is supported by negative spillover. The investigation of negative spillover is a fruitful avenue to better comprehend the reasons why employees' well-being is decreased. Negative spillover occurs when participation in one domain is transferring to restrain the fulfilment of demands in another domain (Cho & Tay, 2016). Negative spillover can come in the form of affection, values, skills and behaviors of work and family domains that can carry over and negatively affect other role responsibilities. It is a necessity to lay emphasis on the negative spillover between work and family domains which is advantageous to the frontline employees as they can understand the ways and know how to cope with multiple work and family demands. Depends on the notion of negative spillover, well-being may be influenced by increased work-family demands through the process of a spillover effect. Apparently, negative spillover arises when perceived high work-family demands developed in one domain are carried over to another domain which engenders the negative effects. By way of illustration, when the frontline employees are grinded down by increased work-family demands, they are more prone to experience high levels of work-family conflict (WFC). Consequently, it will leads to lower satisfaction derived from any facets which in turn negatively affect well-being.

In addition, the findings of this study also devote some important practical implications for the management of the hospitality industry and human resource practitioners. From the practical perspective, the research findings shed some light on the effective management of the employees' well-being. In the present study, the results ascertained that work-family demands act as a dominant factor that will affect the well-being as well as workplace flexibility play a crucial role in moderating the relationship between work-family demands and well-being. Increased work-family demands are the antecedents of WFC. The consequences of WFC are staggering and can negatively affect well-being.

Therefore, the management of the hospitality industry should prioritize employees' well-being by implementing some supportive workplace policies which are provided organizational advantages in conformity with employees' needs such as to furnish workplace flexibility. It is crucial to assist the employees in coping with work-family demands and promoting their well-being by shortening. the lengthy work duration, furnishing an adequate supply of resources to relieve burdensome workloads and managing a good work-life balance. This is also in line with Sustainability Development goals 3 ensure healthy lives and promote well being for all at ages with target to promote retention health workforce in least developed countries.

The research findings also provide significant viewpoints for human resource practitioners. The human resource practitioners will have further insight in encouraging healthy and supportive working conditions as well as devising stress management initiatives which incorporated stress reduction and well-being policies in order to invent positive impacts on employees' well-being. Furthermore, the human resource practitioners also advised to discover potential moderator to enhance the relationship between work family demands and well-being.

### Limitation and Future Research

There are some recommendations for future research that should be proposed in the current study. Since the data collection is adopted self-reported measures to assess these constructs such as work-family demands, well-being and workplace flexibility, thus future researchers are encouraged to contemplate and employ multiple sources of data collection such as gather the data from the respondents' peers, colleagues, superiors, employers and family members in order to strengthen the validity and reliability of results. The present study is emphasized using a cross-sectional study. Nevertheless, the cross-sectional study does not permit for in-depth exploration and draw a decisive conclusion to deduce the causal relationships between the variables of interest. A longitudinal study should be carried out to conclude the causality of research as well as determine the consistency of research



findings. Moreover, future researchers are recommended to conduct qualitative research because the open-ended structures of qualitative research made it possible to provide further probing on the qualitative facet of human perceptions and rational thoughts regarding this study. Therefore, the data collected by utilizing qualitative research will become more in-depth and precise. The results are only applied for the frontline employees in the context of the hospitality industry. The research findings may not applicable in other industries that have differences in nature, hence a comparative study should be implemented across different industries and job positions in order to create different perspectives and broaden the scope of the study.

## VI. ACKNOWLEDGEMENT

This research was sponsored under Special Top Down Grant (SpTDG). Project ID: F04/SpTDG/1775/2018

## REFERENCES

1. Achour, M., Binti Abdul Khalil, S., Binti Ahmad, B., Mohd Nor, M.R., & Zulkifli Bin Mohd Yusoff, M.Y. (2017). Management and supervisory support as a moderator of work–family demands and women’s well-being: A case study of Muslim female academicians in Malaysia. *Humanomics*, 33(3), 335–356. <https://doi.org/10.1108/H-02-2017-0024>
2. Achour, M., Grine, F., & Roslan Mohd Nor, M. (2014). Work-family conflict and coping strategies: Qualitative study of Muslim female academicians in Malaysia. *Mental Health, Religion and Culture*, 17(10), 1002–1014. <https://doi.org/10.1080/13674676.2014.994201>
3. Achour, M., Nor, M.R.M., & Mohd Yusoff, M.Y.Z. (2013). Supervisory support as a moderator of work-family demands and life satisfaction among Malaysian female academicians. *World Applied Sciences Journal*, 28, 32–37. <https://doi.org/10.5829/idosi.wasj.2013.28.efmo.27007>
4. Akkas, M.A., Hossain, M.I., & Rhaman, S. (2015). Causes and Consequences of Work-Family Conflict (WFC) among the Female Employees in Bangladesh: An Empirical Study. *Journal of Business and Economics*, 6(12), 2063–2071. [https://doi.org/10.15341/jbe\(2155-7950\)/12.06.2015/007](https://doi.org/10.15341/jbe(2155-7950)/12.06.2015/007)
5. Annor, F. (2016). Work–family demands and support: Examining direct and moderating influences on work–family conflict. *Journal of Workplace Behavioral Health*, 31(2), 87–103. <https://doi.org/10.1080/15555240.2015.1119656>
6. Boyar, S.L., Carr, J.C., Mosley, D.C., & Carson, C.M. (2007). The development and validation of scores on perceived work and family demand scales. *Educational and Psychological Measurement*, 67(1), 100–115. <https://doi.org/10.1177/0013164406288173>
7. Boyar, S.L., Maertz, C.P., Mosley, D.C., & Carr, J.C. (2008). The impact of work/family demand on work-family conflict. *Journal of Managerial Psychology*, 23(3), 215–235. <https://doi.org/10.1108/02683940810861356>
8. Carlson, D.S., Kacmar, K.M., & Williams, L.J. (2000). Construction and Initial Validation of a Multidimensional Measure of Work-Family Conflict. *Journal of Vocational Behavior*, 56, 249–276. <https://doi.org/10.1006/jvbe.1999.1713>
9. Chiang, F.F.T., Birtch, T.A., & Cai, Z. (2014). Front-line Service Employees’ Job Satisfaction in the Hospitality Industry: The Influence of Job Demand Variability and the Moderating Roles of Job Content and Job Context Factors. *Cornell Hospitality Quarterly*, 55(4), 398–407. <https://doi.org/10.1177/1938965513514628>
10. Cho, E., & Tay, L. (2016). Domain Satisfaction as a Mediator of the Relationship Between Work–Family Spillover and Subjective Well-Being: A Longitudinal Study. *Journal of Business and Psychology*, 31, 445–457. <https://doi.org/10.1007/s10869-015-9423-8>
11. Cleveland, J.N., O’Neill, J.W., Himelright, J.L., Harrison, M.M., Crouter, A.C., & Drago, R. (2007). Work and Family Issues in the Hospitality Industry: Perspectives of Entrants, Managers, and Spouses. *Journal of Hospitality and Tourism Research*, 31(3), 275–298. <https://doi.org/10.1177/1096348007299919>
12. Cohen, J. (1988). *Statistical power for the social sciences*. Hillsdale, NJ: Laurence Erlbaum and Associates.
13. Dawson, M., Abbott, J.A., & Shoemaker, S. (2011). The Hospitality Culture Scale: A measure organizational culture and personal attributes. *International Journal of Hospitality Management*, 30, 290–300. <https://doi.org/10.1016/j.ijhm.2010.10.002>
14. Diamantopoulos, A., & Sigauw, J.A. (2006). Formative versus reflective indicators in organizational measure development: A comparison and empirical illustration. *British Journal of Management*, 17(4), 263–282. <https://doi.org/10.1111/j.1467-8551.2006.00500.x>
15. Dr. Anasica S, Mrs. Sweta Batra. (2020). Analysing the Factors Involved In Risk Management in a Business. *International Journal of New Practices in Management and Engineering*, 9(03), 05 - 10.
16. Edwards, J.R., & Rothbard, N.P. (2000). Mechanisms Linking Work and Family: Clarifying the Relationship between Work and Family Constructs. *Academy of Management Review*, 25(1), 178–199.
17. Erden Bayazit, Z., & Bayazit, M. (2017). How do flexible work arrangements alleviate work-family-conflict? The roles of flexibility i-deals and family-supportive cultures. *The International Journal of Human Resource Management*, 1–31. <https://doi.org/10.1080/09585192.2017.1278615>
18. F. Hair Jr, J., Sarstedt, M., Hopkins, L., & G. Kuppelwieser, V. (2014). Partial least squares structural equation modeling (PLS-SEM). *European Business Review*, 26(2), 106–121. <https://doi.org/10.1108/EBR-10-2013-0128>
19. Franke, G., & Sarstedt, M. (2018). Heuristics versus statistics in discriminant validity testing: a comparison of four procedures. *Internet Research*. <https://doi.org/10.1108/IntR-12-2017-0515>
20. Furtado, L., Sobral, F., & Peci, A. (2016). Linking demands to work-family conflict through boundary strength. *Journal of Managerial Psychology*, 31(8), 1327–1342. <https://doi.org/10.1108/JMP-11-2015-0408>
21. Gamor, E., Amisshah, E.F., Amisshah, A., & Nartey, E. (2017). Factors of work-family conflict in the hospitality industry in Ghana. *Journal of Human Resources in Hospitality and Tourism*, 1–20. <https://doi.org/10.1080/15332845.2017.1328263>
22. Gjerberg, E. (2003). Women doctors in Norway: The challenging balance between career and family life. *Social Science and Medicine*, 57, 1327–1341. [https://doi.org/10.1016/S0277-9536\(02\)00513-0](https://doi.org/10.1016/S0277-9536(02)00513-0)
23. Greenhaus, J.H., & Beutell, N.J. (1985). Sources of Conflict between Work and Family Roles. *The Academy of Management Review*, 10(1), 76–88.
24. Hair, J.F., Sarstedt, M., & Ringle, C.M. (2019). Rethinking some of the rethinking of partial least squares. *European Journal of Marketing*, EJM-10-2018-0665. <https://doi.org/10.1108/EJM-10-2018-0665>
25. Hair, J., Hollingsworth, C.L., Randolph, A.B., & Chong, A.Y.L. (2017). An updated and expanded assessment of PLS-SEM in information systems research. *Industrial Management and Data Systems*, 117(3), 442–458. <https://doi.org/10.1108/IMDS-04-2016-0130>
26. Halpern, D.F. (2005). How time-flexible work policies can reduce stress, improve health, and save money. *Stress and Health*, 21, 157–168. <https://doi.org/10.1002/smi.1049>
27. Henseler, J., Ringle, C.M., & Sarstedt, M. (2014). A new criterion for assessing discriminant validity in variance-based structural equation modeling. *Journal of the Academy of Marketing Science*, 43(1), 115–135. <https://doi.org/10.1007/s11747-014-0403-8>
28. Jeffrey Hill, E., Hawkins, A.J., Ferris, M., & Weitzman, M. (2001). Finding an Extra Day a Week: The Positive Influence of Perceived Job Flexibility on Work and Family Life Balance. *Family Relations*, 50(1), 49–58.
29. Karatepe, O.M., & Baddar, L. (2006). An empirical study of the selected consequences of frontline employees’ work-family conflict and family-work conflict. *Tourism Management*, 27, 1017–1028. <https://doi.org/10.1016/j.tourman.2005.10.024>

30. Kinnunen, U., & Mauno, S. (1998). Antecedents and Outcomes of Work-Family Conflict Among Employed Women and Men in Finland. *Human Relations*, 51(2), 157–177. <https://doi.org/10.1177/0002764213490695>
31. Kline, R.B. (2011). *TXTBK - Principles and Practice of Structural Equation Modeling*. In *Analysis*. <https://doi.org/10.1038/156278a0>
32. Kong, H., Jiang, X., Chan, W., & Zhou, X. (2018). Job satisfaction research in the field of hospitality and tourism. *International Journal of Contemporary Hospitality Management*, 30(5), 2178–2194. <https://doi.org/10.1108/IJCHM-09-2016-0525>
33. Lin, J.H., Wong, J.Y., & Ho, C.H. (2015). The role of work-to-leisure conflict in promoting frontline employees' leisure satisfaction: Examining the job demand-control-support model. *International Journal of Contemporary Hospitality Management*, 27(7), 1539–1555. <https://doi.org/10.1108/IJCHM-03-2014-0155>
34. Lu, L., Kao, S.F., Chang, T.T., Wu, H.P., & Cooper, C.L. (2008). Work/Family Demands, Work Flexibility, Work/Family Conflict, and Their Consequences at Work: A National Probability Sample in Taiwan. *International Journal of Stress Management*, 15(1), 1–21. <https://doi.org/10.1037/1072-5245.15.1.1>
35. Margolis, S., Schwitzgebel, E., Ozer, D.J., & Lyubomirsky, S. (2018). A New Measure of Life Satisfaction: The Riverside Life Satisfaction Scale. *Journal of Personality Assessment*, 1–10. <https://doi.org/10.1080/00223891.2018.1464457>
36. McNall, L.A., Masuda, A.D., & Nicklin, J.M. (2010). Flexible work arrangements, job satisfaction, and turnover intentions: The mediating role of work-to-family enrichment. *The Journal of Psychology*, 144(1), 61–81. <https://doi.org/10.1080/00223980903356073>
37. Michel, J.S., Kotrba, L.M., Mitchelson, J.K., Clark, M.A., & Baltes, B.B. (2011). Antecedents of work-family conflict: A meta-analytic review. *Journal of Organizational Behavior*, 32, 689–725. <https://doi.org/10.1002/job>
38. Moy, P., & Murphy, J. (2016). Problems and prospects in survey research. *Journalism and Mass Communication Quarterly*, 93(1), 16–37. <https://doi.org/10.1177/1077699016631108>
39. Netemeyer, R.G., Boles, J.S., & McMurrian, R. (1996). Development and Validation of Work-Family Conflict and Family-Work Conflict Scales. *Journal of Applied Psychology*, 81(4), 400–410. <https://doi.org/10.1037/0021-9010.81.4.400>
40. Rastogi, M., Rangnekar, S., & Rastogi, R. (2018). Enhancing quality of work life in India: the role of workplace flexibility. *Industrial and Commercial Training*, 50(5), 234–249. <https://doi.org/10.1108/ICT-10-2017-0086>
41. Steffgen, G., Kohl, D., Reese, G., Happ, C., & Sischka, P. (2015). Quality of work: Validation of a new instrument in three languages. *International Journal of Environmental Research and Public Health*, 12, 14988–15006. <https://doi.org/10.3390/ijerph121214958>
42. Wong, J.Y., & Lin, J.H. (2007). The role of job control and job support in adjusting service employee's work-to-leisure conflict. *Tourism Management*, 28, 726–735. <https://doi.org/10.1016/j.tourman.2006.05.003>
43. Zabriskie, R.B., & Ward, P.J. (2013). Satisfaction With Family Life Scale. *Marriage and Family Review*, 49(5), 446–463. <https://doi.org/10.1080/01494929.2013.768321>
44. Zakaria, N., & Ismail, Z. (2017). The Consequences of Work-family Conflict and The Importance of Social Supports to Reduce Work-family Conflict Among Employees. *Malaysian Journal of Social Sciences and Humanities*, 2(2), 25–30.
45. Zhao, X. (Roy). (2016). Work-family studies in the tourism and hospitality contexts. *International Journal of Contemporary Hospitality Management*, 28(11), 2422–2445. <https://doi.org/10.1108/IJCHM-02-2015-0067>
46. Zhao, X. (Roy), & Ghiselli, R. (2016). Why do you feel stressed in a “smile factory”? Hospitality job characteristics influence work–family conflict and job stress. *International Journal of Contemporary Hospitality Management*, 28(2), 305–326. <https://doi.org/10.1108/IJCHM-08-2014-0385>
47. Zhao, X. (Roy), Qu, H., & Ghiselli, R. (2011). Examining the relationship of work-family conflict to job and life satisfaction: A case of hotel sales managers. *International Journal of Hospitality Management*, 30, 46–54. <https://doi.org/10.1016/j.ijhm.2010.04.010>